

MagicCleaner "Stand Alone"

MagicCleaner "Stand Alone" 110 V

GB Operating Instructions
Spare Parts List

TIG power source
(CrNi cleaning)

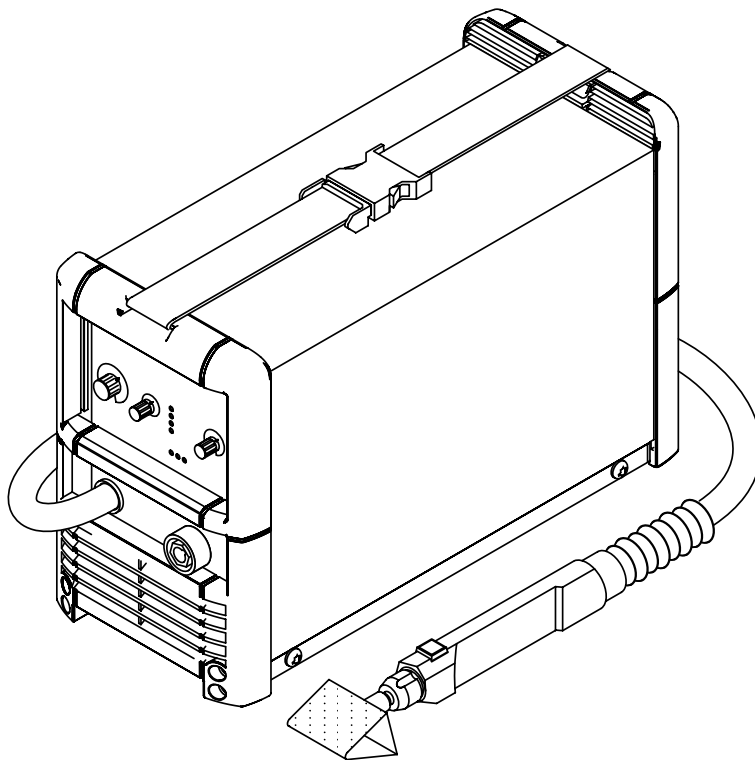

Dear Reader

Introduction

Thank you for choosing Fronius - and congratulations on your new, technically high-grade Fronius product! This instruction manual will help you get to know your new machine. Read the manual carefully and you will soon be familiar with all the many great features of your new Fronius product. This really is the best way to get the most out of all the advantages that your machine has to offer.

Please also take special note of the safety rules - and observe them! In this way, you will help to ensure more safety at your product location. And of course, if you treat your product carefully, this definitely helps to prolong its enduring quality and reliability - things which are both essential prerequisites for getting outstanding results.



Safety rules

DANGER!



“**DANGER!**” indicates an imminently hazardous situation which, if not avoided, will result in death or serious injury. This signal word is to be limited to the most extreme situations. This signal word is not used for property damage hazards unless personal injury risk appropriate to this level is also involved.



WARNING!



“**WARNING!**” indicates a potentially hazardous situation which, if not avoided, could result in death or serious injury. This signal word is not used for property damage hazards unless personal injury risk appropriate to this level is also involved.

CAUTION!



“**CAUTION!**” indicates a potentially hazardous situation which, if not avoided, may result in minor or moderate injury. It may also be used to alert against unsafe practices that may cause property damage.

NOTE!



“**NOTE!**” indicates a situation which implies a risk of impaired welding result and damage to the equipment.

Important!

“**Important!**” indicates practical hints and other useful special-information. It is no signal word for a harmful or dangerous situation.

Whenever you see any of the symbols shown above, you must pay even closer attention to the contents of the manual!

General remarks



This equipment has been made in accordance with the state of the art and all recognised safety rules. Nevertheless, incorrect operation or misuse may still lead to danger for

- the life and well-being of the operator or of third parties,
- the equipment and other tangible assets belonging to the owner/operator,
- efficient working with the equipment.

All persons involved in any way with starting up, operating, servicing and maintaining the equipment must

- be suitably qualified
- read and follow exactly the instructions given in this manual.

The instruction manual must be kept at the machine location at all times. In addition to the instruction manual, copies of both the generally applicable and the local accident prevention and environmental protection rules must be kept on hand, and of course observed in practice.

All the safety instructions and danger warnings on the machine itself:

- must be kept in a legible condition
- must not be damaged
- must not be removed
- must not be covered, pasted or painted over

General remarks
(continued)

- must not be removed
- must not be covered, pasted or painted over

It's your safety that's at stake!

Utilisation for intended purpose only



The machine may only be used for jobs as defined by the "Intended purpose".
Utilisation for any other purpose, or in any other manner, shall be deemed to be "not in accordance with the intended purpose". The manufacturer shall not be liable for any damage resulting from such improper use.

- Utilisation in accordance with the "intended purpose" also comprises
- complete reading and following of all the instructions given in this manual
 - complete reading and following of all the safety instructions and danger warnings
 - performing all stipulated inspection and servicing work.

The machine is designed to be used in industrial and workshop environments. The manufacturer shall not be liable for any damage resulting from use of the machine in residential premises.

Likewise Fronius will accept no liability for defective or faulty work results.

Ambient conditions



Operation or storage of the machine outside the stipulated range is deemed to be "not in accordance with the intended use". The manufacturer shall not be liable for any damage resulting herefrom.

Temperature range of ambient air:

- when operating: - 10 °C to + 40 °C (14 °F to 104 °F)
- when being transported or stored: - 25 °C to + 55 °C (-13 °F to 131 °F)

Relative atmospheric humidity:

- up to 50 % at 40 °C (104 °F)
- up to 90 % at 20 °C (68 °F)

Ambient air: Free of dust, acids, corrosive gases or substances etc.

Elevation above sea level: Up to 2000 m (6500 ft)

Obligations of owner/operator



The owner/operator undertakes to ensure that the only persons allowed to work with the machine are persons who

- are familiar with the basic regulations on workplace safety and accident prevention and who have been instructed in how to operate the machine
- have read and understood the sections on "safety rules" and the "warnings" contained in this manual, and have confirmed as much with their signatures
- be trained in such a way that meets with the requirements of the work results

Regular checks must be performed to ensure that personnel are still working in a safety-conscious manner.

Obligations of personnel

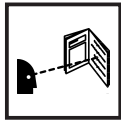

- Before starting work, all persons to be entrusted with carrying out work with (or on) the machine shall undertake
- to observe the basic regulations on workplace safety and accident prevention
 - to read the sections on “safety rules” and the “warnings” contained in this manual, and to sign to confirm that they have understood these and will comply with them.

Before leaving the workplace, personnel must ensure that there is no risk of injury or damage being caused during their absence.

Protection for yourself and other persons



- When working with this machine, you are exposed to many different hazards such as:
- irritation and/or cauterization of skin in case of contact with cleaning agent (cleaning electrolyte, brightening electrolyte, electrolyte powder and printing electrolyte)
 - danger of serious eye injury in case of contact with cleaning agent
 - general hazards when handling chemicals



- electrical hazards from mains and cleaning current



- harmful vapours



Anybody working on the workpiece during cleaning must wear suitable protective clothing with the following characteristics:

- resistant against acids and chemicals
- isolating and dry
- must cover whole body, be undamaged and in good condition

“Protective clothing” also includes:



- wearing a pair of appropriate regulation goggles (with sideguards)



- wearing stout footwear that will also insulate even in wet conditions



- wearing protective gloves (hand protection), impermeable, resistant against acids and chemicals



- wearing protective apron (e.g. when refilling chemicals)

Immediately remove any working garment contaminated with cleaning agent!



Protection for yourself and other persons
(continued)



- Don't eat and drink during working
- Keep cleaning agent away from food, drink and fodder



- Wash your hands before breaks and at the end of a working day



Keep other people - especially children, pregnant women and sick persons - well away from the equipment and the working operation while this is in progress. If there are still any other persons nearby during working, you must

- draw their attention to all the dangers
- provide them with suitable protective equipment and/or
- erect suitable protective partitions or curtains.

Instructions for the correct handling of cleaning agents

The following aspects must be observed when handling cleaning agents (cleaning electrolyte, brightening electrolyte, electrolyte powder and printing electrolyte). For more detailed data please refer to the relevant safety data sheets. You will find the current safety data sheets on the Fronius-Homepage under <http://www.fronius.com>.



First-aid measures

- After inhaling of vapours provide for supply of fresh air. In case of complaint see a doctor.
- After contact with skin wash with water and soap and rinse carefully. In case of continued irritation of skin see a doctor.
- After swallowing do not cause vomiting. Rinse mouth and drink a lot of water, see a doctor immediately.



- After contact with eyes rinse eyes several minutes under running water with eyelid open (eye shower) and see a doctor.

Storage / safekeeping

- Use only containers especially approved for cleaning agents
- Keep container closed tightly
- Don't store together with alkali (lyes) and metals
- Store in a cool and dry place
- Provide for acid-proof floor



- Keep under lock and key and without the reach of children

Other instructions

- Don't heat to avoid thermal decomposition (development of toxic gases)
- Provide for emergency cooling in case of fire close by
- Avoid contact with eyes, skin and mucous membranes
- Use only in well ventilated areas. In case of insufficient ventilation use respiratory protection
- For diluting always put acid into water - not the other way round!
- Dispose of cleaning agents and/or uncleaned packagings as provided by national regulations. Don't dispose together with domestic waste!



- Don't let agent get into drain system, into waters or the ground water (e.g. via the ground).

Hazards from mains and cleaning current



An electric shock can be fatal. Every electric shock is hazardous to life.

Do not touch any live parts, either inside or outside the machine.

Ensure sufficient protection for yourself and for other people by means of a dry base or cover that provides adequate insulation against the ground/frame potential. The base or cover must completely cover the entire area between your body and the ground/frame potential.

All cables and other leads must be firmly attached, undamaged, properly insulated and adequately dimensioned. Immediately replace any loose connections, scorched, damaged or underdimensioned cables or other leads.

Do not loop any cables or other leads around your body or any part of your body.

Have the mains and the machine supply leads checked regularly by a qualified electrician to ensure that the PE (protective earth) conductor is functioning correctly.

Only run the machine on a mains network with a PE conductor, and plugged into a power outlet socket with a protective-conductor contact.

If the machine is run on a mains network without a PE conductor and plugged into a power outlet socket without a protective-conductor contact, this counts as gross negligence and the manufacturer shall not be liable for any resulting damage.

Wherever necessary, use suitable measures to ensure that the workpiece is sufficiently grounded (earthed).

Switch off any appliances that are not in use.

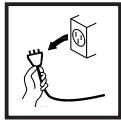

Before doing any work on the machine, switch it off and unplug it from the mains.

Put up a clearly legible and easy-to-understand warning sign to stop anybody inadvertently plugging the machine back into the mains and switching it back on again.

After opening up the machine:

- discharge any components that may be storing an electrical charge
- ensure that all machine components are electrically dead.

If work needs to be performed on any live parts, there must be a second person on hand to immediately switch off the machine at the main switch in an emergency.

EMC precautions



It is the responsibility of the owner/operator to ensure that no electromagnetic interference is caused to electrical and electronic equipment.

If electromagnetic interference is found to be occurring, the owner/operator is obliged to take all necessary measures to prevent this interference.

Examine and evaluate any possible electromagnetic problems that may occur on equipment in the vicinity, and the degree of immunity of this equipment, in accordance with national and international regulations:

- safety features



EMC precautions (continued)

- mains, signal and data-transmission leads
- IT and telecoms equipment
- measurement and calibration devices
- the health of persons in the vicinity, e.g. users of heart pacemakers and hearing aids
- users of heart pacemakers must take medical advice before going anywhere near welding equipment or welding workplaces

Electromagnetic fields may cause as yet unknown damage to health.

Ancillary measures for preventing EMC problems:

- a) Mains supply
 - If electromagnetic interference still occurs, despite the fact that the mains connection is in accordance with the regulations, take additional measures (e.g. use a suitable mains filter).
- b) Power supply lines
 - Keep these as short as possible
 - Arrange them so that they run close together
 - Lay them well away from other leads.
- c) Equipotential bonding
- d) Workpiece grounding (earthing)
 - where necessary, run the connection to ground (earth) via suitable capacitors.
- e) Shielding, where necessary
 - Shield other equipment in the vicinity
 - Shield the entire welding installation.

Particular danger spots

Covers and sideguards may only be opened or removed for as long as is absolutely necessary to carry out maintenance and repair work.

While the machine is in use:

- ensure that all the covers are closed and that all the sideguards are properly mounted ...
- ... and that all covers and sideguards are kept closed.



Special regulations apply to rooms at risk from fire and/or explosion. Observe all relevant national and international regulations.



Power sources for use in spaces with increased electrical danger (e.g. boilers) must be identified by the  (for "safety") mark.

If a machine is fitted with a carrying strap or carrying handle, remember that this strap is ONLY to be used for lifting and carrying the machine by hand. The carrying strap is NOT suitable for transporting the machine by crane, fork-lift truck or by any other mechanical hoisting device.



Measurement of pollutant emissions while working with the device revealed values below the admissible mean toxic limit.

Nevertheless:

- Provide for sufficient supply of fresh air.
- Keep head away from generated vapours.
- Don't inhale generated vapours and/or exhaust them from working area by appropriate means.

Safety precautions at the installation site and when being transported

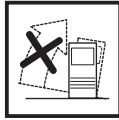

A machine that topples over can easily kill someone! For this reason, always place the machine on an even, firm floor in such a way that it stands firmly.

- An angle of inclination of up to 10° is permissible.



Special regulations apply to rooms at risk from fire and/or explosion. Observe all relevant national and international regulations.

By means of internal instructions and checks, ensure that the workplace and the area around it are always kept clean and tidy.

The appliance must only be installed and operated in accordance with the protection type stated on the specifications plate.

When installing the appliance, please ensure a clearance radius of 0.5 m (1.6 ft.) , so that cool air can circulate freely.

When transporting the appliance, please ensure that the valid national and regional guidelines and accident protection regulations are followed. This applies in particular to guidelines in respect of dangers during transportation and carriage.

Before transportation, completely drain any cleaning agent.

Before commissioning and after transportation, a visual check for damage must be carried out. Any damage must be repaired by Fronius-trained service personnel before commissioning.

Safety precautions in normal operation



Only operate the machine if all of its protective features are fully functional. If any of the protective features are not fully functional, this endangers:

- the life and well-being of the operator or other persons
- the equipment and other tangible assets belonging to the owner/operator
- efficient working with the equipment.

Any safety features that are not fully functional must be put right before you switch on the machine.

Never evade safety features and never put safety features out of order.

Before switching on the machine, ensure that nobody can be endangered by your doing so.

- At least once a week, check the machine for any damage that may be visible from the outside, and check that the safety features all function correctly.
- Only Fronius cleaning agent is suitable for use in our machines.
- Do not mix Fronius cleaning agent with other cleaning agents.
- If any damage occurs in cases where other cleaning agents have been used, the manufacturer shall not be liable for any such damage, and all warranty claims shall be null and void.
- Only transport the cleaning agent in closed original containers.



Preventive and corrective maintenance



With parts sourced from other suppliers, there is no certainty that these parts will have been designed and manufactured to cope with the stressing and safety requirements that will be made of them. Use only original spares and wearing parts (this also applies to standard parts).

Do not make any alterations, installations or modifications to the machine without getting permission from the manufacturer first.

Replace immediately any components that are not in perfect condition.

When ordering spare parts, please state the exact designation and the relevant part number, as given in the spare parts list. Please also quote the serial number of your machine.

The device, the sideguards and the mechanical components may be earthed only by means of „Extrude-Tite“ screws.

Safety inspection



The owner/operator is obliged to have a safety inspection performed on the machine at least once every 12 months.

A safety inspection, by a trained and certified electrician, is prescribed:

- after any alterations
- after any modifications or installations of additional components
- following repairs, care and maintenance
- at least every twelve months.

Observe the relevant national and international standards and directives in connection with the safety inspection.

More detailed information on safety inspections and calibration is available from your regional or national Fronius service centre, who will be pleased to provide you with copies of the necessary documents upon request.

Safety markings



Equipment with CE-markings fulfils the basic requirements of the Low-Voltage and Electromagnetic Compatibility Guideline (e.g. relevant product standards according to EN 60 974).



Equipment marked with the CSA-Test Mark fulfils the requirements made in the relevant standards for Canada and the USA.

Copyright



Copyright to this instruction manual remains the property of Fronius International GmbH.

The text and illustrations are all technically correct at the time of going to print. The right to effect modifications is reserved. The contents of the instruction manual shall not provide the basis for any claims whatever on the part of the purchaser. If you have any suggestions for improvement, or can point out to us any mistakes which you may have found in the manual, we should be most grateful for your comments.

Table of contents

General Remarks	2
General Remarks	2
Design concept	2
Functional sequence	2
Utilization for intended purpose only	3
Setting-up instructions	3
Transport Requirements	3
Options	3
Mains connection	4
MagicCleaner	4
MagicCleaner 110 V	4
Technical data	5
MagicCleaner	5
MagicCleaner 110 V	5
Controls, connections and mechanical components	6
General remarks	6
Controls	6
Connections and mechanical components	7
Operating modes	9
Manual cleaning	9
Auto cleaning	9
Polishing / burnishing	9
Printing	9
Cleaning , polishing / burnishing	10
General remarks	10
Preparation	10
Fitting a new cleaning cloth on the cleaning electrode	10
Start-up	10
Cleaning procedure	11
Removal of electrolyte and heavy metal residues	11
Printing, if MagicCleaner is exclusively used for printing	12
General remarks	12
Imprinting film for short-term use	12
Preparation	12
Mount the printing felt on the cleaning electrode	12
Start-up	13
Printing procedure	13
Printing, if MagicCleaner is used for cleaning, polishing/burnishing and for printing	14
General remarks	14
Imprinting film for short-term use	14
Preparation	14
Mount the printing felt on the cleaning electrode	14
Start-up	15
Printing procedure	15
Care, maintenance and disposal	16
General remarks	16
Every start-up	16
Weekly	16
Every 6 months	16
Disposal	16
Spare parts list	
Fronius Worldwide	

General Remarks

General Remarks



Fig.1 MagicCleaner „Stand alone“

The MagicCleaner CrNi cleaning unit opens up brand-new dimensions in weld finishing. With the aid of processor-controlled current curves and a specially formulated electrolyte, the unit achieves cleaning results of unparalleled quality. The unit's automatic, exactly controllable electrolyte-dispensing system guarantees a high level of safety and ease of handling. Thanks to its unique cleaning qualities, its area of use ranges from craft and trade workshops all the way up to the food-processing and chemical industries.

Design concept

The unit's powder-coated sheet-steel housing, shielded controls (in a recess protected by a plastic surround) and its bayonet-latching earth socket are all features designed to prolong its service life. Its shoulder strap makes it easy to carry around, both indoors in the workshop and outdoors on site-erection jobs.

Functional sequence

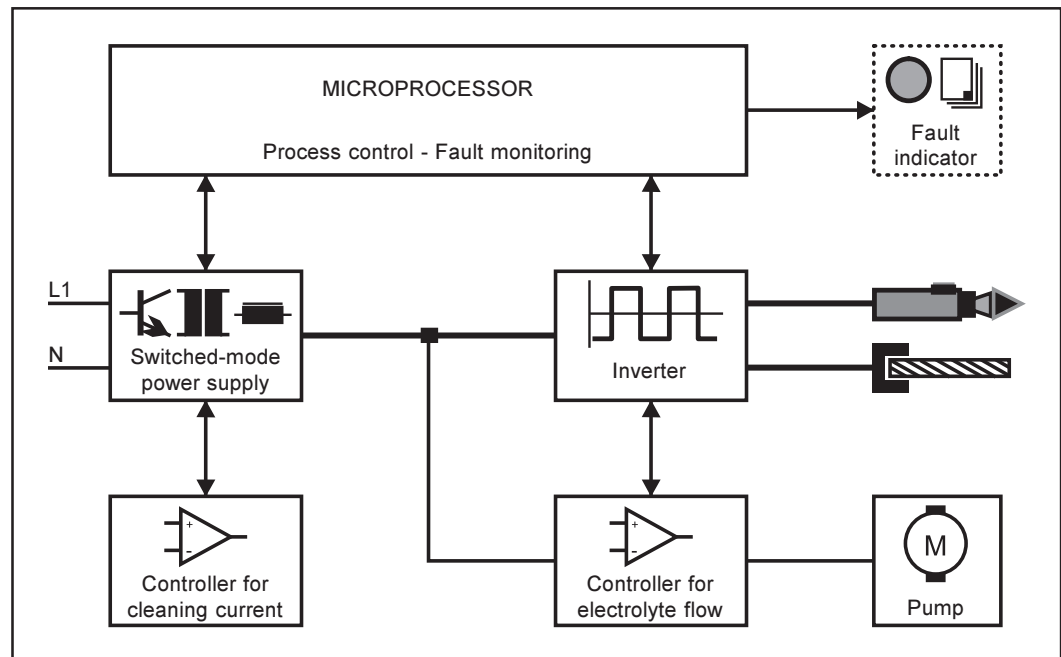

Fig. 1 Block diagram of "Stand alone" MagicCleaner

The mains voltage is regulated to operating voltage via an isolated switched-mode power supply and the adjusted operating current. via a A series-connected inverter transforms the DC voltage into a 50 Hz square-wave voltage and supplies this to the output. Electronic controllers adjust the cleaning current and electrolyte dispensing rate to suit the intended utilisation. The cleaning process as a whole is controlled and monitored by a microprocessor.



Utilization for intended purpose only

The MagicCleaner is exclusively designed for the electro-chemical cleaning of high-alloy steels.
Utilisation for any other purpose, or in any other manner, shall be deemed to be "not in accordance with the intended purpose". The manufacturer shall not be liable for any damage resulting from such improper use.

Utilisation in accordance with the "intended purpose" also comprises

- the instructions given in this manual
- performing all stipulated inspection and servicing work.

Setting-up instructions

Open-air operation

In view of the unit's IP 23 protection rating, it is suitable for outdoor placement and operation. However, the built-in electrical components must be protected from direct wetting such as that caused by external wet-cleaning.

Ambient temperature

Important! The temperatures for employment and storage must not fall below the following values:

- without electrolyte -25°C
- with electrolyte -10°C

The cleaning unit must be positioned well away from such sources of heat as radiators, heating or annealing furnaces, direct hot sunshine etc., which would raise its temperature still further.

Transport Requirements



NOTE! Before being transported the reservoir must be emptied completely! Otherwise the MagicCleaner would have to be packed and marked as hazardous material.

Options

MagicCleaner suction device

Fully automatic, portable unit for exhausting the fumes generated by the electro-chemical cleaning process.

Carbon electrode

The high-strength graphite composite cleaning electrode allows to speed up the cleaning process by 20 - 30 %, depending on the type of metal used.

Mains connection

MagicCleaner The “Stand alone” MagicCleaner may be operated as standard on a mains voltage of 230V. Yellow-green lead = protective earth conductor (PE). The other conductors L_1 and N are connected to the phase and neutral conductors of the mains plug.

Important! Electrical work, fitting or changing the power plug, may only be carried out by a qualified electrician!

MagicCleaner 110 V The “Stand alone” MagicCleaner 110 V may be operated as standard on a mains voltage of 100 - 110 V. Yellow-green lead = protective earth conductor (PE). The other conductors L_1 and N are connected to the phase and neutral conductors of the mains plug.

Technical data

MagicCleaner

Unit suitable for use in confined spaces	S
Mains voltage -15%/+10%	~230 V / 50-60 Hz
Mains fuse	10 A Ⓢ
Apparent power	490 VA
Output current	5 - 20 A
Output voltage	2 - 12 V
Output power	200 W
Open-circuit voltage	17 V
Dispensing rate	0.55 - 2.2 l/h
Cleaning agent capacity	1.5 l
Degree of protection	IP 23
Dimension l/b/h	430/180/280 mm
Weight	5 kg
Pollutant emission during operation (measured acc. to VDI 2462, part 8)	phosphoric acid (H ₃ PO ₄) < 0.2 mg/m ³ sulphuric acid (H ₂ SO ₄) < 0.6 mg/m ³

MagicCleaner 110 V

Unit suitable for use in confined spaces	S
Mains voltage -6%/+6%	~100-110 V / 50-60 Hz
Mains fuse	10 A Ⓢ
Apparent power	490 VA
Output current	5 - 20 A
Output voltage	2 - 12 V
Output power	200 W
Open-circuit voltage	17 V
Dispensing rate	0.55 - 2.2 l/h
Cleaning agent capacity	1.5 l
Degree of protection	IP 23
Dimension l/b/h	430/180/280 mm
Weight	8,4 kg
Pollutant emission during operation (measured acc. to VDI 2462, part 8)	phosphoric acid (H ₃ PO ₄) < 0.2 mg/m ³ sulphuric acid (H ₂ SO ₄) < 0.6 mg/m ³

Controls, connections and mechanical components

General remarks



WARNING! Operating the equipment incorrectly can cause serious injury and damage. Do not use the functions described here until you have read and completely understood all of the following documents:

- these Operating Instructions
- all "Operating Instructions" for the system components, especially the "Safety rules"

Controls

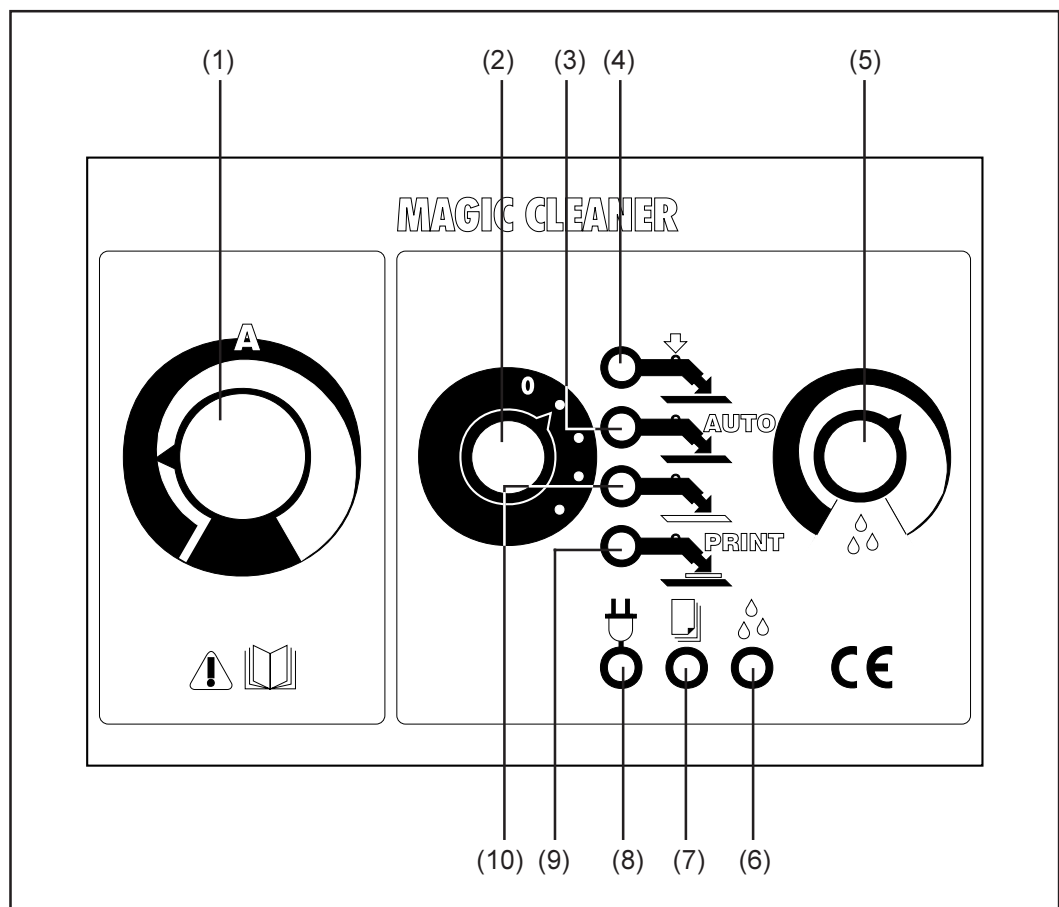

Fig.4 Controls

- (1) **Cleaning-current dial**
 - Continuous adjustment of cleaning current from 5-20 A
- (2) **Program switch**
 - for switching the MagicCleaner from stand-by to the desired operating mode.
- (3) **LED indicator "Auto-Cleaning" mode**
 - lights up when the "Auto-Cleaning" mode is selected
- (4) **LED indicator "Manual-Cleaning" mode**
 - lights up when the "Manual-Cleaning" mode is selected

Controls
(continued)

- (5) **Dial for electrolyte dispensing rate**
 - Continuous adjustment of electrolyte dispensing rate from 0.55 - 2.2 l/h
- (6) **“Elektrolyte dispensing” LED**
 - lights up when the pump is in operation
- (7) **LED “Fault” indicator**
 - lights up if the unit is overloaded (if the temperature of the power section reaches 65°C).
 - flashes if short-circuiting occurs between the stylus and earth (e.g. cleaning cloth is defective)
- (8) **“Stand-by” LED**
 - lights up when the MagicCleaner is connected to the mains
- (9) **LED indicator “Printing“ mode**
 - lights up when the “Printing“ mode is selected
- (10) **LED indicator “Polishing / Burnishing“ mode**
 - lights up when the “Polishing / Burnishing“ mode is selected

Connections and mechanical components



- (11) **Handle with cleaning electrode and cleaning cloth**
for creating the electrical and electrolytic connection between the MagicCleaner and the workpiece
- (12) **Bayonet-latching earth socket**
for connecting the earth cable

Fig. 5 View from front, with cleaning handle



Connections and mechanical components
(continued)



Fig. 6 Rear view, showing accessories

(13) Storage compartment

for storing the accessories supplied with the unit.

These include:

- 1 pc. safety goggles
- 1 pair of protection gloves
- 10 pcs. spare cleaning cloths
- 1 case of Fronius electrolyte powder
- 1 pc. mixing container 1 l



CAUTION! Danger of injury because of acid and/or acid residues. Don't keep cleaning liquids, contaminated gloves and used cleaning rags in the storage compartment. Store mixing container in the storage compartment only when cleaned!

Operating modes

Manual cleaning

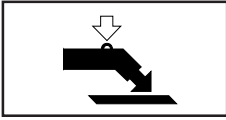

“Manual Cleaning” mode serves for removing tarnish discoloration
The Electrolyte is dispensed when the button is pushed on the cleaning handle (polishing not possible)

Current curve: AC

Auto cleaning

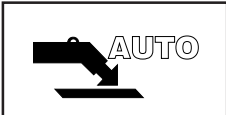

“Auto-Cleaning” mode serves for removing tarnish discoloration
The electrolyte is automatically dispensed during cleaning. Adjustment of the desired dispensing rate with dial for electrolyte dispensing rate (5). No need to push the button! (Polishing not possible)

Current curve: AC

Polishing / burnishing

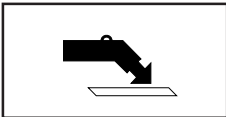

“Polishing / Burnishing” mode serves for polishing (burnishing) the workpiece after cleaning

The electrolyte is dispensed when the button is pushed on the cleaning handle

Current curve: DC

Printing

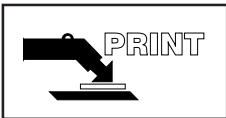

“Printing” mode serves for electrochemical printing of CrNi parts (e.g. graphics or company logos).

Current curve: AC



Cleaning , polishing / burnishing

General remarks



WARNING! Operating the equipment incorrectly can cause serious injury and damage. Do not use the functions described here until you have read and completely understood all of the following documents:

- these Operating Instructions
- all "Operating Instructions" for the system components, especially the "Safety rules"
- the safety data sheet for the cleaning and brightening electrolyte as well as for Fronius electrolyte powder

Preparation

1. Take safety precautions: Put on safety goggles, gloves and protective clothing
2. Switch off the MagicCleaner and disconnect it from the mains supply
3. Undo the screw-cap of the reservoir
4. Only for use of Fronius electrolyte powder: prepare electrolyte powder as cleaning electrolyte
 - a) Fill 1/2 l of clear water into the mixing container included in the scope of supply
 - b) Add complete contents of the case containing Fronius electrolyte powder slowly to water
 - c) Close mixing container tightly.
 - d) Shake mixing container with water and Fronius electrolyte powder for approx. 1 min.
 - e) Open mixing container and pour in the remaining 1/2 l of water
 - f) Again close mixing container tightly
 - g) Shake mixing container for another 1 min (until Fronius electrolyte powder is completely dissolved).
5. Fill the reservoir with cleaning or polishing electrolyte up to just under the filler neck. Clean mixing container for preparation of Fronius electrolyte powder, if necessary.

Important! Use only original Fronius cleaning or polishing electrolyte!

6. Replace the screw-cap of the reservoir tightly
7. Make an earth connection between the MagicCleaner and the workpiece

Fitting a new cleaning cloth on the cleaning electrode

1. Using your index finger and thumb, pull the clamping plate towards the cleaning handle and turn it 90°
2. Using your thumb, lift the clamping plate on each side at a time and clamp the cleaning cloth in place
3. Turn the clamping plate back 90°

Start-up



CAUTION! Danger of damage to workpiece and cleaning electrode because of current flow. As soon as the mains cable of the MagicCleaner is connected to the mains, cleaning current may be flowing, if the program switch is positioned accordingly.

Deposit handle on insulated surface!

1. Connect up the MagicCleaner to the mains
2. Select the desired operating mode with the program switch (2)
3. Select the cleaning current on dial (1) and the electrolyte dispensing rate on dial (5).

Cleaning procedure

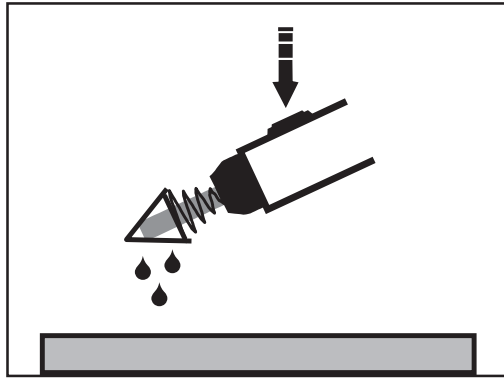

Fig.7 Wet the cleaning cloth with electrolyte

1. Push the button on the handle to wet sufficiently the stretched cleaning cloth with electrolyte

The first time after the reservoir has been (re)filled, it takes the electrolyte approx. 30 sec to be pumped from the reservoir to the handle

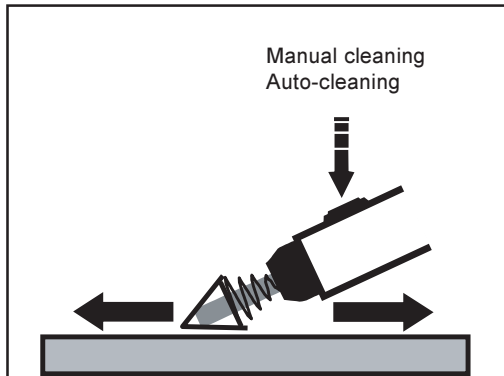

Fig.8 Cleaning procedure

2. Applying gentle pressure, move the cleaning electrode back and forward along the tarnished weld and continuously moisten the cleaning cloth with electrolyte



NOTE: During the cleaning procedure do not dwell on the same spot for too long, as due to the increasing thermal load wear of the cleaning cloth increases significantly!
Also ensure that the cleaning cloth is always moistened with sufficient electrolyte!

Removal of electrolyte and heavy metal residues

Electrochemical cleaning with the MagicCleaner leaves electrolyte and heavy metal residues on the workpiece surface. Such residues may cause deposits on the workpiece and affect corrosion resistance!

1. Soak a clean sponge in clean water.
2. Wipe the electrochemically treated surfaces with the wet sponge.
3. Rinse the sponge.
4. Repeat several times.



NOTE! During electrochemical cleaning ensure that no cleaning electrolyte enters into the workpiece cavities. In most cases complete removal of electrolyte residue from cavities can only be achieved with great difficulty.



Printing, if MagicCleaner is exclusively used for printing

General remarks



WARNING! Operating the equipment incorrectly can cause serious injury and damage. Do not use the functions described here until you have read and completely understood all of the following documents:

- these Operating Instructions
- all "Operating Instructions" for the system components, especially the "Safety rules"
- the safety data sheet for the printing electrolyte.

For this application, we recommend using the "Printing set (4,100,212 - not included in MagicCleaner scope of supply). This set consists of:

- Printing electrolyte 0.5l
- 1 x printing film for doing your own printing
- 10 x printing felts
- 1 x plastic canister
- 1 x plastic case

Imprinting film for short-term use

Use a dot matrix printer or a mechanical typewriter for imprinting the film for short-term use.

1. Fix the film to a paper sheet size A4 with adhesive tape
2. Insert paper into printer in a way that the colored film is printed
3. Print text or graphics on the film
4. Remove colored printing film

The printing film can be used for abt 10 printings.

Preparation

1. Switch off the MagicCleaner disconnect it from the mains
2. Undo the screw-cap of the reservoir

Important! Before pouring the printing electrolyte into the reservoir, this must first be emptied completely! Also, the hosepack and reservoir must be rinsed with clean water!

3. Fill the reservoir with printing electrolyte, up to just under the filler neck
4. Replace the screw-cap of the reservoir tightly
5. Make an earth connection between the MagicCleaner and the workpiece

Mount the printing felt on the cleaning electrode

1. Using your index finger and thumb, pull the clamping plate towards the cleaning handle and turn it 90°
2. Using your thumb, lift the clamping plate on each side at a time and clamp the printing-felt in place
3. Turn the clamping plate back 90°

Start-up



CAUTION! Danger of damage to workpiece and cleaning electrode because of current flow. As soon as the mains cable of the MagicCleaner is connected to the mains, cleaning current may be flowing, if the program switch is positioned accordingly.

Deposit handle on insulated surface!

1. Connect up the MagicCleaner to the mains
2. Select the Printing mode with the program switch (2)
3. Select the cleaning current on dial (1) and set the electrolyte dispensing rate to maximum on dial (5)
4. Fix the printing film to the workpiece with adhesive tape

Printing procedure

1. Push the button on the handle to ensure that the printing felt is sufficiently wetted with electrolyte.

The first time after the reservoir has been (re)filled, it takes the electrolyte approx. 30 sec to be pumped from the reservoir to the handle

2. Applying gentle pressure, slowly move the cleaning electrode across the film, 1 - 3 times

Important! When you have finished printing, rinse the printing film thoroughly in water (if the printing electrolyte dries onto the film, this may lead to poor-quality printing results)!



NOTE! If the cleaning electrode touches the workpiece off the edge of the film, this causes black marks on the workpiece!

Printing, if MagicCleaner is used for cleaning, polishing/burnishing and for printing

General remarks



WARNING! Operating the equipment incorrectly can cause serious injury and damage. Do not use the functions described here until you have read and completely understood all of the following documents:

- these Operating Instructions
- all "Operating Instructions" for the system components, especially the "Safety rules"
- the safety data sheet for the cleaning and brightening electrolyte, Fronius electrolyte powder and the printing electrolyte

For this application, we recommend using the "Printing set (4,100,212 - not included in MagicCleaner scope of supply). This set consists of:

- Printing electrolyte 0.5l
- 1 x printing film for doing your own printing
- 10 x printing felts
- 1 x plastic canister
- 1 x plastic case

Imprinting film for short-term use

Use a dot matrix printer or a mechanical typewriter for imprinting the film for short-term use.

1. Fix the film to a paper sheet size A4 with adhesive tape
2. Insert paper into printer in a way that the colored film is printed
3. Print text or graphics on the film
4. Remove colored printing film

The printing film can be used for abt 10 printings.

Preparation

1. Switch off the MagicCleaner and disconnect it from the mains
2. Pour the printing electrolyte into a plastic canister
3. Remove the cleaning cloth from the cleaning electrode and rinse the electrode well with water
4. Make an earth connection between the MagicCleaner and the workpiece

Mount the printing felt on the cleaning electrode

1. Using your index finger and thumb, pull the clamping plate towards the cleaning handle and turn it 90°
2. Using your thumb, lift the clamping plate on each side at a time and clamp the printing-felt in place
3. Turn the clamping plate back 90°

Start-up



CAUTION! Danger of damage to workpiece and cleaning electrode because of current flow. As soon as the mains cable of the MagicCleaner is connected to the mains, cleaning current may be flowing, if the program switch is positioned accordingly.

Deposit handle on insulated surface!

1. Connect up the MagicCleaner to the mains
2. Select the "Printing" mode with the program switch (2)
3. Set the cleaning current to maximum on dial (1) and the electrolyte dispensing rate to minimum on dial (5)
4. Fix the printing film to the workpiece with adhesive plastic tape

Printing procedure

1. Dip the cleaning electrode, with the mounted printing felt, into the printing electrolyte until the felt is well wetted.
2. Applying gentle pressure, slowly move the cleaning electrode across the film, 1 - 3 times

Important! When you have finished printing, rinse the printing film thoroughly in water (if the printing electrolyte dries onto the film, this may lead to poor-quality printing results)!



NOTE! If the cleaning electrode touches the workpiece off the edge of the film, this causes black marks on the workpiece!

Care, maintenance and disposal

General remarks Under normal operating conditions the MagicCleaner requires only a minimum of care and maintenance. However, it is indispensable to follow some important points to ensure the operability of the machine for many years.



WARNING! An electric shock can be fatal. Before opening up the machine:

- shift the mains switch into the "O" position
- unplug the machine from the mains
- put up an easy-to-understand warning sign to stop anybody inadvertently switching it back on again
- using a suitable measuring instrument, check to make sure that electrically charged components (e.g. capacitors) have been discharged

Every start-up

- Check mains cable and interconnecting cable for damage
- Check container and pump for leakage
- Check whether the allround distance of 0.5 m (1ft. 8in.) is kept to ensure that the cooling air can easily flow and escape.



NOTE! Furthermore, air inlets and outlets must in no case be covered, not even covered partly.

Weekly

Clean device by means of solvent-free products.

Every 6 months

- Dismantle machine side panels and clean machine inside with dry reduced compressed air



NOTE! Risk of damage to electronic components. Clean electronic components from a certain distance only.

- If a lot of dust has accumulated, clean the cooling-air ducts.

Disposal

Carry out disposal in accordance with the valid national and local regulations.

(D) Ersatzteilliste

(GB) Spare Parts List

(F) Liste de pièces de rechange

(I) Lista parti di ricambio

(E) Lista de repuestos

(P) Lista de peças sobresselentes

(NL) Onderdelenlijst

(N) Reservdeliste

(CZ) Seznam náhradních dílů

(RUS) Список запасных частей

MagicCleaner Stand Alone
MagicCleaner Stand Alone Japanese
MagicCleaner Stand Alone 100-115/230V

4,075,092
4,075,092,360
4,075,092,361

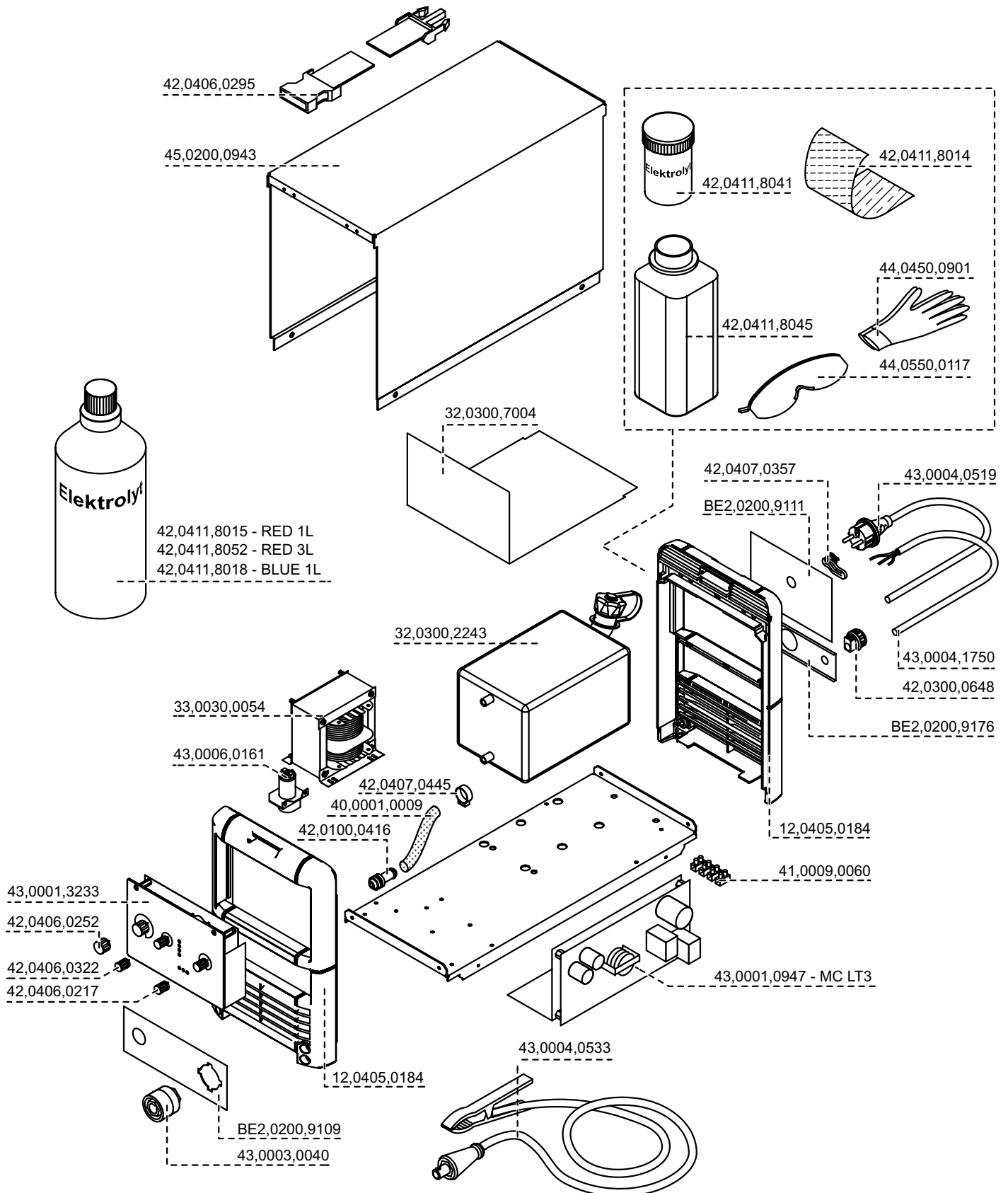

MagicCleaner

Ersatzteilliste / Spare parts list / Listes de pièces de rechange / Lista de repuestos / Lista de peças sobresselentes / Lista dei Ricambi

1/1

el_fr_st_cn_00073 012006



POS.	BENENNUNG	ARTICLE	DENOMINATION	
1	PRINTFILZ FÜR MAGIC CLEANER	PRINT- FELT FOR MAGIC CLEANER	IMPRIMER FEUTRE POUR MAGIC CL.	42.0300.7030
2	ELEKTROLYT PRINTEN 0,5 L	ELECTROLYTE PRINT 0,5L	ELECTROLYTE DE IMPRIMER 0,5L	42.0411.8021
3	ELEKTROLYT PRINTEN 1,0 L	ELECTROLYTE PRINT 1,0L	ELECTROLYTE DE IMPRIMER 1,0L	42.0411.8022
4	PRINTFOLIE EINWEG 65X195 MM	PRINT FOIL 65X195 MM	IMPRIMER FEUILLE MET. 65X195 M	42.0411.8023
5	KUNSTSTOFFDOSE F.MAGIC-CLEANER	PLASTIC-BOX F.MAGIC CLEANER	PLASTIQUE-BAC MAGIC GLEANER	42.0411.8012
6	ERSATZTEILBOX M.SCHAUMSTOFF	SPARE PART BOX WITH INLET	BOITE CONSOMMABLES	42.0409.2638



PRINT - SET 1 MAGIC CLEANER 4,100,212

Ersatzteilliste / Spare parts list / Listes de pièces de rechange / Lista de repuestos / Lista de peças sobresselentes / Lista dei Ricambi

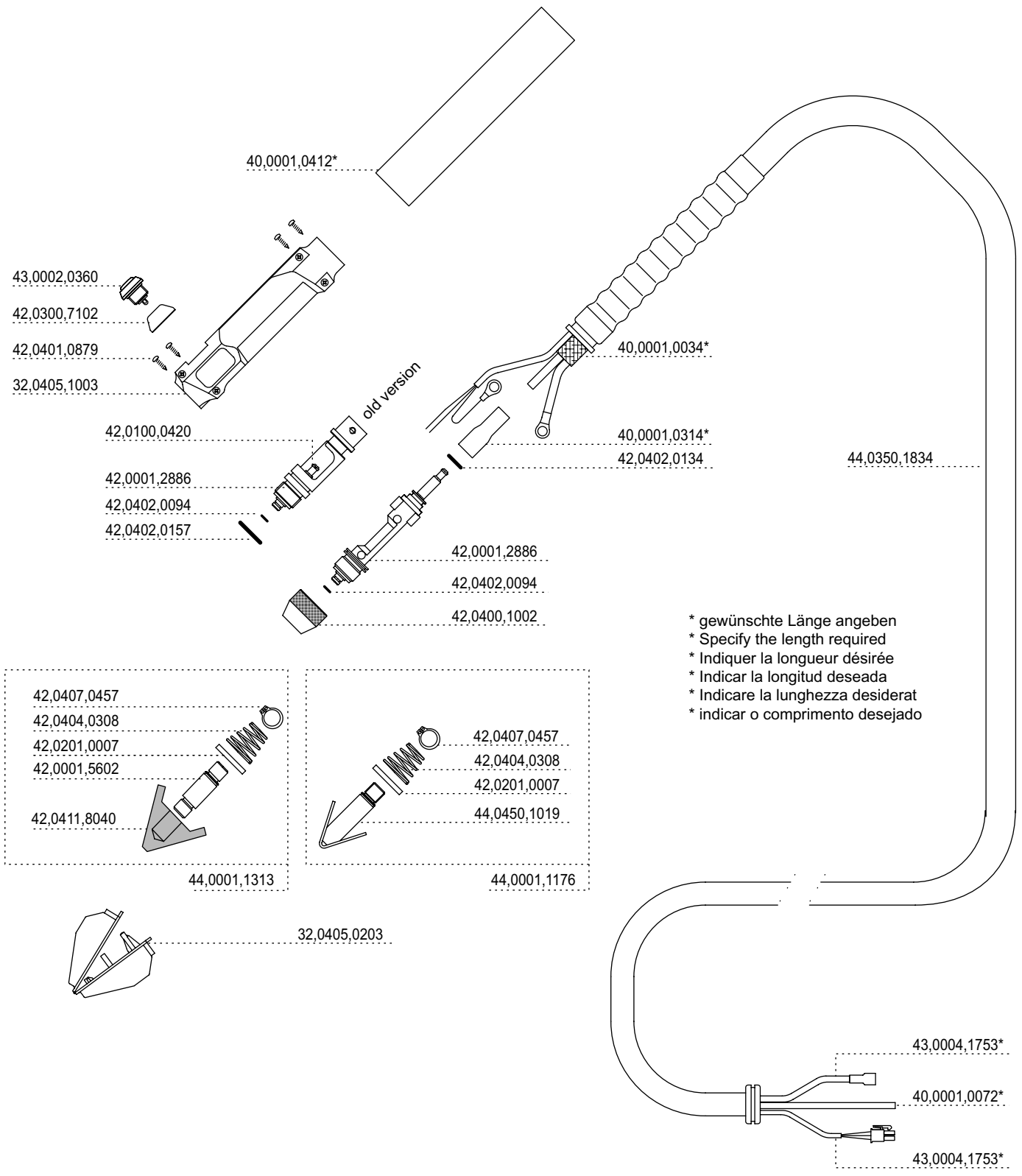

* gewünschte Länge angeben
 * Specify the length required
 * Indiquer la longueur désirée
 * Indicar la longitud deseada
 * Indicare la lunghezza desiderata
 * indicar o comprimento desejado



Hose pack

Ersatzteilliste / Spare parts list / Listes de pièces de rechange / Lista de repuestos / Lista de peças sobresselentes / Lista dei Ricambi

Fronius Worldwide - www.fronius.com/addresses

A **FRONIUS International GmbH**
4600 Wels, Buxbaumstraße 2
Tel: +43 (0)7242 241-0
Fax: +43 (0)7242 241-3940
E-Mail: sales@fronius.com
<http://www.fronius.com>

4600 Wels, Buxbaumstraße 2
Tel: +43 (0)7242 241-0
Fax: +43 (0)7242 241-3490
Service: DW 3070, 3400
Ersatzteile: DW 3390
E-Mail: sales.austria@fronius.com

6020 Innsbruck, Amraserstraße 56
Tel: +43 (0)512 343275-0
Fax: +43 (0)512 343275-725

5020 Salzburg, Lieferinger Hauptstr.128
Tel: +43 (0)662 430763
Fax: +43 (0)662 430763-16

1100 Wien, Daumegasse 7,
Team Süd / Ost
Tel: +43 (0)1/600 41 02-7410
Fax: +43 (0)1/600 41 02-7490
Team Nord / West
Tel: +43 (0)1/600 41 02-7050
Fax: +43 (0)1/600 41 02-7160

Haberkorn Ulmer GmbH
6961 Wolfurt, Hohe Brücke
Tel: +43 (0)5574 695-0
Fax: +43 (0)5574 2139
<http://www.haberkorn.com>

Wilhelm Zultner & Co.
8042 Graz, Schmiedstraße 7
Tel: +43 (0)316 6095-0
Fax: +43 (0)316 6095-80
Service: DW 325, Ersatzteile: DW 335
E-Mail: vkm@zultner.at

Wilhelm Zultner & Co.
9020 Klagenfurt, Fallegasse 3
Tel: +43 (0)463 382121-0
Fax: +43 (0)463 382121-40
Service: DW 430, Ersatzteile: DW 431
E-Mail: vkk@zultner.at

BR **FRONIUS do Brasil LTDA**
Av. Senador Vergueiro, 3260
Vila Tereza, Sao Bernado do Campo - SP
CEP 09600-000, SÃO PAULO
Tel: +55 (0)11 4368-3355
Fax: +55 (0)11 4177-3660
E-Mail: sales.brazil@fronius.com

CH **FRONIUS Schweiz AG**
1513 Rümlang, Oberglatterstraße 11
Tel: +41 (0)1817 9944
Fax: +41 (0)1817 9955
E-Mail: sales.switzerland@fronius.com

CZ **FRONIUS Ěeská republika s.r.o.**
381 01 ĚESKÝ KRUMLOV, Tovární 170
Tel: +420 380 705 111
Fax: +420 380 711 284
E-Mail: sales.c.krumlov@fronius.com

100 00 PRAHA 10, V Olšinách 1022/42
Tel.: +420 272 111 011, 272 742 369
Fax: +420 272 738 145
E-Mail: sales.praha@fronius.com

315 00 PLZEŇ-Bořkov, Letkovská 38
Tel: +420 377 183 411
Fax: +420 377 183 419
E-Mail: sales.plzen@fronius.com

500 04 HRADEC KRÁLOVÉ,
Pražská 293/12
Tel.: +420 495 070 011
Fax: +420 495 070 019
E-Mail: sales.h.kralove@fronius.com

CZ 586 01 JIHLAVA, Brninská 65
Tel: +420 567 584 911
Fax: +420 567 305 978
E-Mail: sales.jihlava@fronius.com

709 00 OSTRAVA - Mariánské Hory,
Kollárova 3
Tel: +420 595 693 811
Fax: +420 596 617 223
E-Mail: sales.ostrava@fronius.com

760 01 ZLÍN
ul. Malá (za ěerp. st. ARAL)
Tel: +420 577 311 011
Fax: +420 577 311 019
E-Mail: sales.zlin@fronius.com

D **FRONIUS Deutschland GmbH**
67661 Kaiserslautern, Liebigstraße 15
Tel: +49 (0)631 35127-0
Fax: +49 (0)631 35127-50
E-Mail: sales.germany@fronius.com

90530 Wendelstein,
Wilhelm-Maisel-Straße 32
Tel: +49 (0)9129 2855-0
Fax: +49 (0)9129 2855-32

51149 Köln, Gremberghoven,
Welslerstraße 10 b
Tel: +49 (0)2203 97701-0
Fax: +49 (0)2203 97701-10

57052 Siegen, Alcher Straße 51
Tel: +49 (0)271 37515-0
Fax: +49 (0)271 37515-15

38640 Goslar, Im Schleeke 108
Tel: +49 (0)5321 3413-0
Fax: +49 (0)5321 3413-31

10365 Berlin, Josef-Orlopp-Str. 92-106
Tel: +49 (0)30 557745-0
Fax: +49 (0)30 557745-51

21493 Talkau, Dorfstraße 4
Tel: +49 (0)4156 8120-0
Fax: +49 (0)4156 8120-20

70771 Leinfelden-Echterdingen
(Stuttgart),
Kolumbus-Straße 47
Tel: +49 (0)711 782852-0
Fax: +49 (0)711 782852-10

04328 Leipzig, Riesaer Straße 72-74
Tel: +49 (0)341 27117-0
Fax: +49 (0)341 27117-10

01723 Kesselsdorf (Dresden),
Zum alten Dessauer 13
Tel: +49 (0)35204 7899-0
Fax: +49 (0)35204 7899-10

67753 Hefersweiler, Sonnenstraße 2
Tel: +49 (0)6363 993070
Fax: +49 (0)6363 993072

18059 Rostock, Erich Schlesinger Str. 50
Tel: +49 (0)381 4445802
Fax: +49 (0)381 4445803

81379 München, Gmunder Straße 37a
Tel: +49 (0)89 748476-0
Fax: +49 (0)89 748476-10

83308 Trostberg, Pechleraustraße 7
Tel: +49 (0)8621 8065-0
Fax: +49 (0)8621 8065-10

94491 Hengersberg, Donaustraße 31
Tel: +49 (0)9901 2008-0
Fax: +49 (0)9901 2008-10

F **FRONIUS France SARL**
60306 SENLIS CEDEX,
13 avenue Félix Louat - B.P.195
Tél: +33 (0)3 44 63 80 00
Fax: +33 (0)3 44 63 80 01
E-Mail: sales.france@fronius.com

N **FRONIUS Norge AS**
3056 Solbergelva, P.O. BOX 32
Tel: +47 (0)32 232080,
Fax: +47 (0)32 232081
E-Mail: sales.norway@fronius.com

SK **FRONIUS Slovensko s.r.o.**
917 01 Trnava, Nitrianská 5
Tel: +421 (0)33 590 7511
Fax: +421 (0)33 590 7599
E-Mail: sales.slovakia@fronius.com

974 03 Banská Bystrica,
Zvolenská cesta 14
Tel: +421 (0)48 472 0611
Fax: +421 (0)48 472 0699
E-Mail: sales.b.bystrica@fronius.com

UA **FRONIUS Ukraine GmbH**
07455 Ukraine, Kiwskaya OBL.,,
S. Knjashitschi, Browarskogo R-NA
Tel: +38 044 94-62768
+38 044 94-54170
Fax: +38 044 94-62767
E-Mail: sales.ukraine@fronius.com

USA **FRONIUS USA LLC**
10503 Citation Drive,
Brighton, Michigan 48116
Tel: +1(0) 810 220-4414
Fax: +1(0) 810 220-4424
E-Mail: sales.usa@fronius.com

Under <http://www.fronius.com/addresses> you will find all addresses of our sales branches and partner firms!