

/ Perfect Welding / Solar Energy / Perfect Charging



Fronius International GmbH
Strategic Product Management IWS
Froniusplatz 1, 4600 Wels
Austria

FANUC
120iD

FANUC 120iD

PUSH -- BASIC

4,049,036 WF 25i R /PAP/4R/G/W/FSC
4x 44,0001,1407 Feeder Roll FSR U 1,2mm

4,101,196 WF MOUNTING QuickSlide Fanuc

Gascooled version:

4,047,876 HP 70i CON R /G/4m
4,101,080 Mounting extension hose pack

Watercooled version:

4,047,880 HP 70i CON R /W/4m
4,101,080 Mounting extension hose pack

8m 40,0001,0527 Wire feed hose
4,100,890 OPT/I WF Quick Connect
4,100,896 OPT/I WF Quick Connect Coil

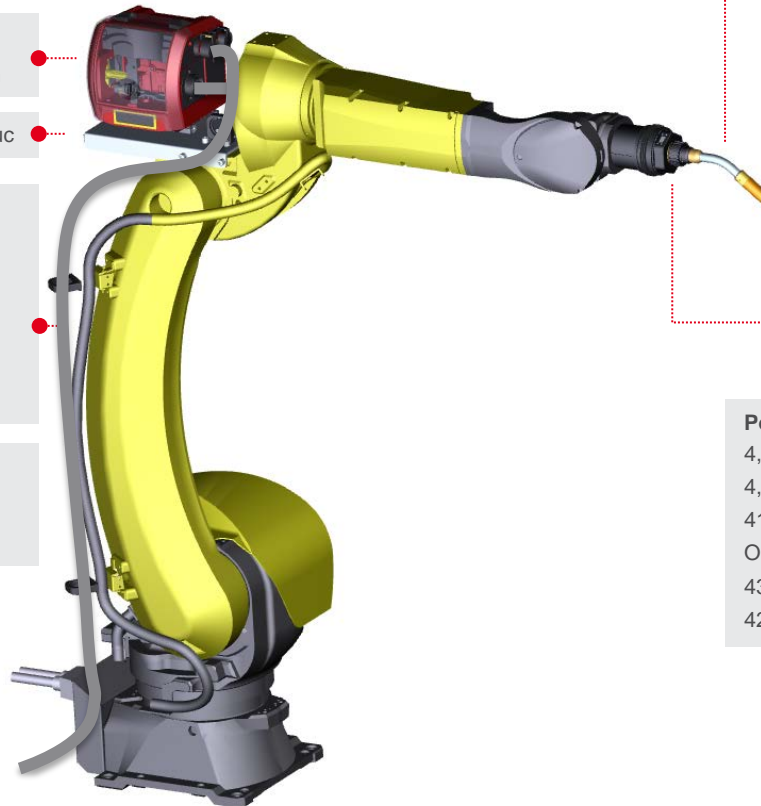

Gascooled version:

4,047,905 MHP 400i R/G/PAP/FSC/1,15m
44,0350,3465 MTB 400i G R/22°/L241/L50
44,0350,5120 BK Fe ø1,2 G/W/5m

Watercooled version:

4,047,921 MHP 700i R/W/PAP/FSC/1,15m
44,0350,3494 MTB 500i W R/22°/L241/H50
44,0350,5120 BK Fe ø1,2 G/W/5m

44,0350,4392 RFP i 64 PAP 8M4 71
44,0350,3663 CrashBox /i PAP L

PowerSource:

4,075,172 TPS 320i
4,044,035 RI FB/i Fanuc 1.0
41,0018,0084 RI MOD/i CC Ethernet/IP
Only W: 4,048,003 CU 1100i
43,0004,2262 Earth cable 70mm² 10m + cable lug
42,0510,0011 Pressure control valve Ar/CO₂ 3-30l/min

FANUC 120iD

PUSH -- STANDARD

4,049,036 WF 25i R /PAP/4R/G/W/FSC
4x 44,0001,1407 Feeder Roll FSR U 1,2mm

4,101,196 WF MOUNTING QuickSlide Fanuc

Gascooled version:

4,047,878 HP 70i CON R /G/8m
4,101,080 Mounting extension hose pack

Watercooled version:

4,047,883 HP 70i CON R /W/8m
4,101,080 Mounting extension hose pack

8m 40,0001,0527 Wire feed hose
4,100,890 OPT/I WF Quick Connect
4,100,896 OPT/I WF Quick Connect Coil

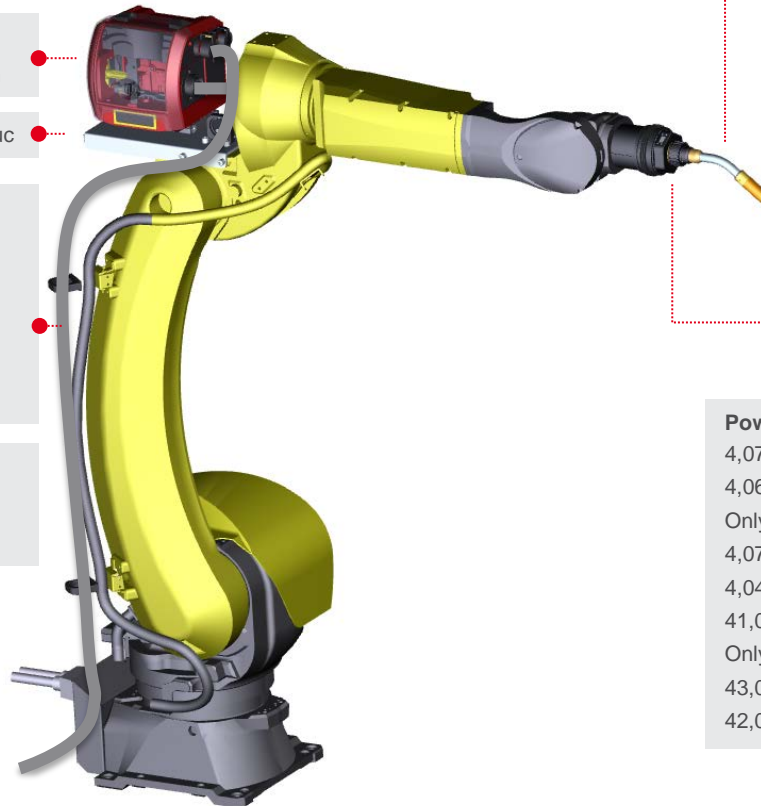

Gascooled version:

4,047,905 MHP 400i R/G/PAP/FSC/1,15m
44,0350,3465 MTB 400i G R/22°/L241/L50
44,0350,5120 BK Fe ø1,2 G/W/5m

Watercooled version:

4,047,921 MHP 700i R/W/PAP/FSC/1,15m
44,0350,3494 MTB 500i W R/22°/L241/H50
44,0350,5120 BK Fe ø1,2 G/W/5m

44,0350,4392 RFP i 64 PAP 8M4 71
44,0350,3663 CrashBox /i PAP L

PowerSource:

4,075,174 TPS 400i
4,066,013 Welding Process Pulse
Only W: 4,100,808,IK OPT/i TPS 2. NT241 CU 1400i /IK
4,077,001 Podium
4,044,035 RI FB/i Fanuc 1.0
41,0018,0084 RI MOD/i CC Ethernet/IP
Only W: 4,048,004 CU 1400i Pro
43,0004,2262 Earth cable 70mm² 10m + cable lug
42,0510,0011 Pressure control valve Ar/CO2 3-30l/min

FANUC 120iD PUSH -- PRO

4,049,036 WF 25i R /PAP/4R/G/W/FSC
4x 44,0001,1407 Feeder Roll FSR U 1,2mm

4,101,196 WF MOUNTING QuickSlide Fanuc

Gascooled version:

4,047,836 HP 95i CON /G/5m
4,047,889 HP 95i EXT R /G/3m
4,101,080 Mounting extension hose pack

Watercooled version:

4,047,848 HP 95i CON /W/5m
4,047,891 HP 95i EXT R /W/3m
4,101,080 Mounting extension hose pack

8m 40,0001,0527 Wire feed hose
4,100,890 OPT/I WF Quick Connect
4,100,896 OPT/I WF Quick Connect Coil

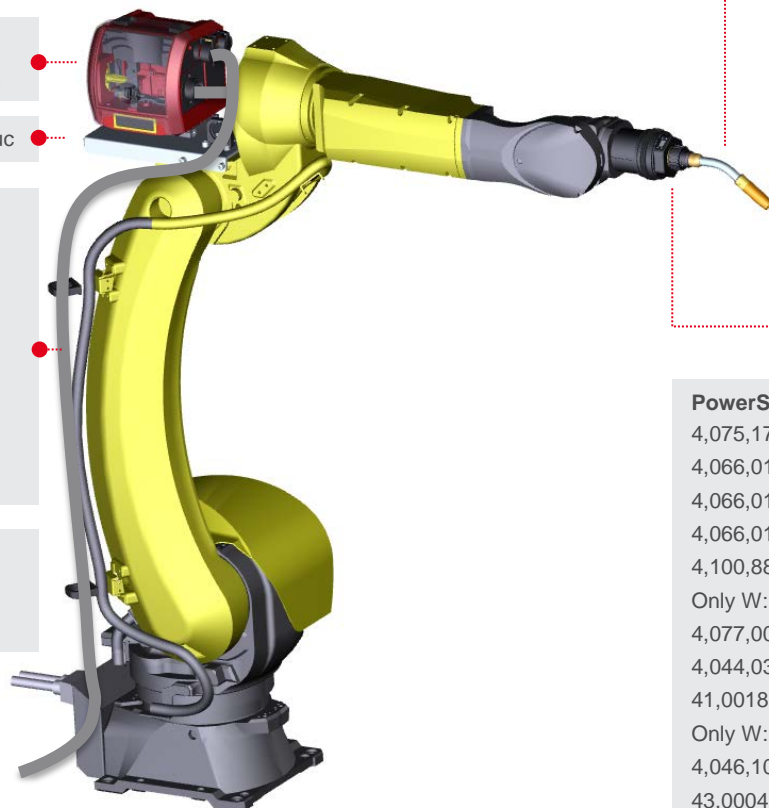

Gascooled version:

4,047,905 MHP 400i R/G/PAP/FSC/1,15m
44,0350,3465 MTB 400i G R/22°/L241/L50
44,0350,5120 BK Fe ø1,2 G/W/5m

Watercooled version:

4,047,921 MHP 700i R/W/PAP/FSC/1,15m
44,0350,3494 MTB 500i W R/22°/L241/H50
44,0350,5120 BK Fe ø1,2 G/W/5m

44,0350,4392 RFP i 64 PAP 8M4 71

44,0350,3663 CrashBox /i PAP L

PowerSource:

4,075,176 TPS 500i
4,066,013 Welding Process Pulse
4,066,014 Welding Process LSC
4,066,015 Welding Process PMC
4,100,886,IK OPT/i TPS 4x Switch SpeedNet
Only W: 4,100,808,IK OPT/i TPS 2. NT241 CU 1400i /IK
4,077,001 Podium
4,044,035 RI FB/i Fanuc 1.0
41,0018,0084 RI MOD/i CC Ethernet/IP
Only W: 4,048,004,633 CU 1400i Pro/MC
4,046,105 RC Panel Standard /5m
43,0004,2130 Earth cable 95mm² 10m + earth clamp
42,0510,0011 Pressure control valve Ar/CO₂ 3-30l/min

FANUC 120iD POWER DRIVE

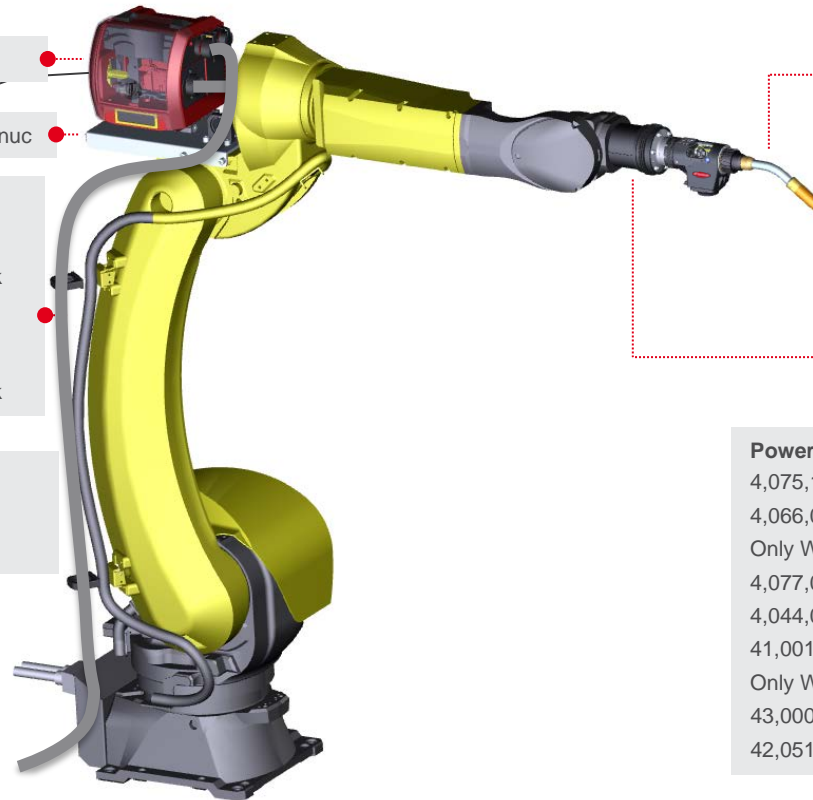

4,040,081 SB 500i R/PAP/G/W/FSC

4,101,196 WF MOUNTING QuickSlide Fanuc

Gascooled version:

4,047,878 HP 70i CON R /G/8m

4,101,080 Mounting extension hose pack

Watercooled version:

4,047,883 HP 70i CON R /W/8m

4,101,080 Mounting extension hose pack

5m 40,0001,0527 Wire feed hose

4,100,890 OPT/I WF Quick Connect

4,100,896 OPT/I WF Quick Connect Coil

Gascooled version:

4,047,937 MHP 400i RD/G/PAP/FSC/1,135m

4,036,389 WF 25i Robacta Drive/G

44,0350,3465 MTB 400i G R/22°/L241/H50

44,0350,5285 BK RD AL ø1,2 /G CuSi /G /W

Watercooled version:

4,047,953 MHP 500i
RD/W/PAP/FSC/1,135m

4,036,388 WF 25i Robacta Drive/W

44,0350,3495 MTB 500i W R/36°/L224/H86

44,0350,5292 BK RD Al ø1,2 /W

44,0350,4392 RFP i 64 PAP 8M4 71

44,0350,3379 CrashBox Drive /i PAP XL

PowerSource:

4,075,179 TPS 400i PULSE

4,066,015 Welding Process PMC

Only W: 4,100,808,IK OPT/i TPS 2. NT241 CU 1400i /IK

4,077,001 Podium

4,044,035 RI FB/i Fanuc 1.0

41,0018,0084 RI MOD/i CC Ethernet/IP

Only W: 4,048,004,633 CU 1400i Pro MC

43,0004,2262 Earth cable 70mm² 10m + cable lug

42,0510,0011 Pressure control valve Ar/CO2 3-30l/min

FANUC 120iD PUSHPULL -- DRIVE

4,040,081 SB 500i R/PAP/G/W/FSC

4,101,196 WF MOUNTING QuickSlide Fanuc

Gascooled version:

4,047,878 HP 70i CON R /G/8m

4,101,080 Mounting extension hose pack

Watercooled version:

4,047,883 HP 70i CON R /W/8m

4,101,080 Mounting extension hose pack

10m 40,0001,0527 Wire feed hose

2x 4,100,890 OPT/I WF Quick Connect

4,100,845 WF Mounting Drum

4,049,039 WF 30i REEL R/2R

42,0001,4582 Drive roll 1,2

44,0001,3430 Pressure roll 1,2

4,051,022 OPT/I SpeedNet Cable CON 5m

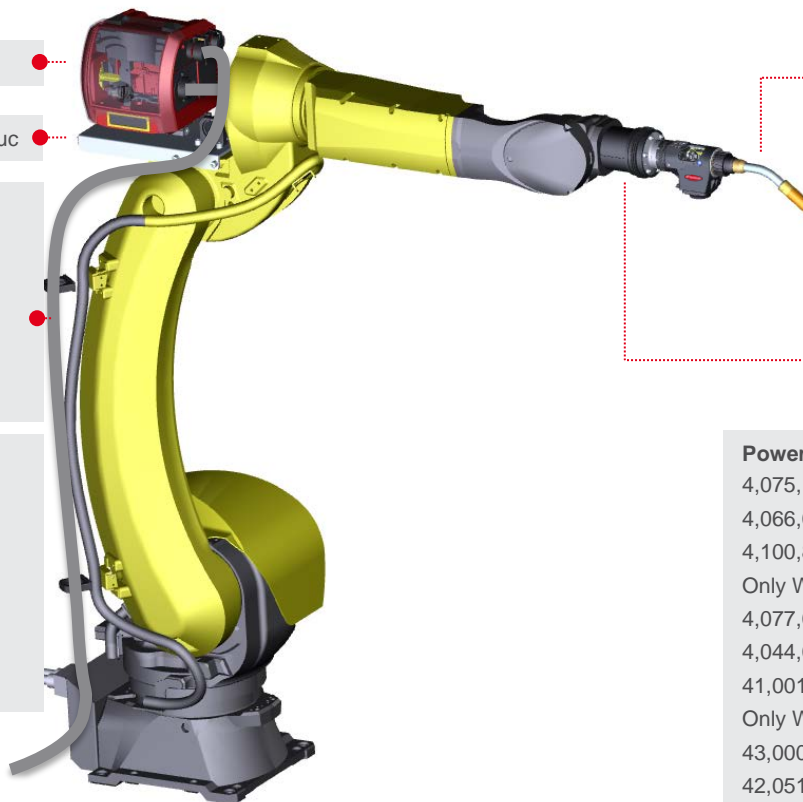

Gascooled version:

4,047,937 MHP 400i RD/G/PAP/FSC/1,135m

4,036,389 WF 25i Robacta Drive/G

44,0350,3465 MTB 400i G R/22°/L241/H50

44,0350,5285 BK RD AL ø1,2 /G CuSi /G /W

Watercooled version:

4,047,953 MHP 500i
RD/W/PAP/FSC/1,135m

4,036,388 WF 25i Robacta Drive/W

44,0350,3495 MTB 500i W R/36°/L224/H86

44,0350,5292 BK RD Al ø1,2 /W

44,0350,4392 RFP i 64 PAP 8M4 71

44,0350,3379 CrashBox Drive /i PAP XL

PowerSource:

4,075,179 TPS 400i PULSE

4,066,015 Welding Process PMC

4,100,886,IK OPT/i TPS 4xSwitch SpeedNet

Only W: 4,100,808,IK OPT/i TPS 2. NT241 CU 1400i /IK

4,077,001 Podium

4,044,035 RI FB/i Fanuc 1.0

41,0018,0084 RI MOD/i CC Ethernet/IP

Only W: 4,048,004,633 CU 1400i Pro MC

43,0004,2262 Earth cable 70mm² 10m + cable lug

42,0510,0011 Pressure control valve Ar/CO₂ 3-30l/min

FANUC 120iD PUSHPULL -- CMT

4,040,081 SB 500i R/PAP/G/W/FSC
4,100,774,IK OPT/i External Sensor Plug

4,101,196 WF MOUNTING QuickSlide Fanuc

Gascooled version:

4,047,878 HP 70i CON R /G/8m

Watercooled version:

4,047,883 HP 70i CON R /W/8m

4,101,199 Mounting CMT Fanuc5

4,001,763 Wire buffer set CMT TPS/i

2x 4,100,890 OPT/I WF Quick Connect

4,100,845 WF Mounting Drum

4,049,041 WF 25i REEL R/4R

4x 44,0001,1407 wire feed roll U1,2

4,051,022 OPT/I SpeedNet Cable CON 5m

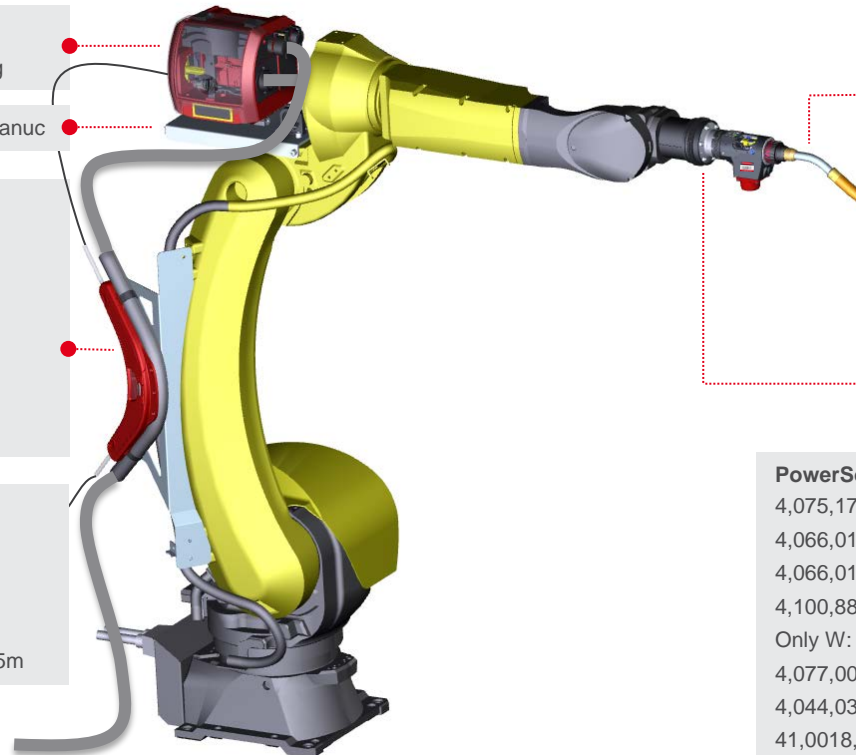

Gascooled version:

4,047,937 MHP 400i
RD/G/PAP/FSC/1,135m

4,036,391 WF 60i Robacta Drive CMT/G

44,0350,3465 MTB 400i G R/22°/L241/H50

44,0350,5316 BK CMT RD Al ø1,2 G

Watercooled version:

4,047,953 MHP 500i
RD/W/PAP/FSC/1,135m

4,036,390 WF 60i Robacta Drive CMT/W

44,0350,3495 MTB 500i W R/36°/L224/H86

44,0350,5322 BK CMT Al ø1,2/W

44,0350,4392 RFP i 64 PAP 8M4 71

44,0350,3379 CrashBox Drive /i PAP XL

PowerSource:

4,075,174 TPS 400i

4,066,013 Welding Process Pulse

4,066,016 Welding Process CMT

4,100,886,IK OPT/i TPS 4xSwitch SpeedNet

Only W: 4,100,808,IK OPT/i TPS 2. NT241 CU 1400i /IK

4,077,001 Podium

4,044,035 RI FB/i Fanuc 1.0

41,0018,0084 RI MOD/i CC Ethernet/IP

Only W: 4,048,004,633 CU 1400i Pro MC

43,0004,2262 Earth cable 70mm² 10m cable lug

42,0510,0011 Pressure control valve Ar/CO₂ 3-30l/min

FANUC 120iD

PUSHPULL -- CMT (SB 60i)

Gascooled version:

4,040,087 SB60i
4,051,202,1K HP 70i CON SB60 G 8m
4,101,082 MOUNTING SB60 Fanuc3

Watercooled version:

4,040,087 SB60i
4,051,204,1K HP 70i CON SB60 W 8m
4,101,082 MOUNTING SB60 Fanuc3

6m 40,0001,0527 Wire feed hose
2x 4,100,890 OPT/I WF Quick Connect
4,100,845 WF Mounting Drum
4,049,041 WF 25i REEL R/4R
4x 44,0001,1407 wire feed roll U1,2
4,051,022 OPT/I SpeedNet Cable CON 5m

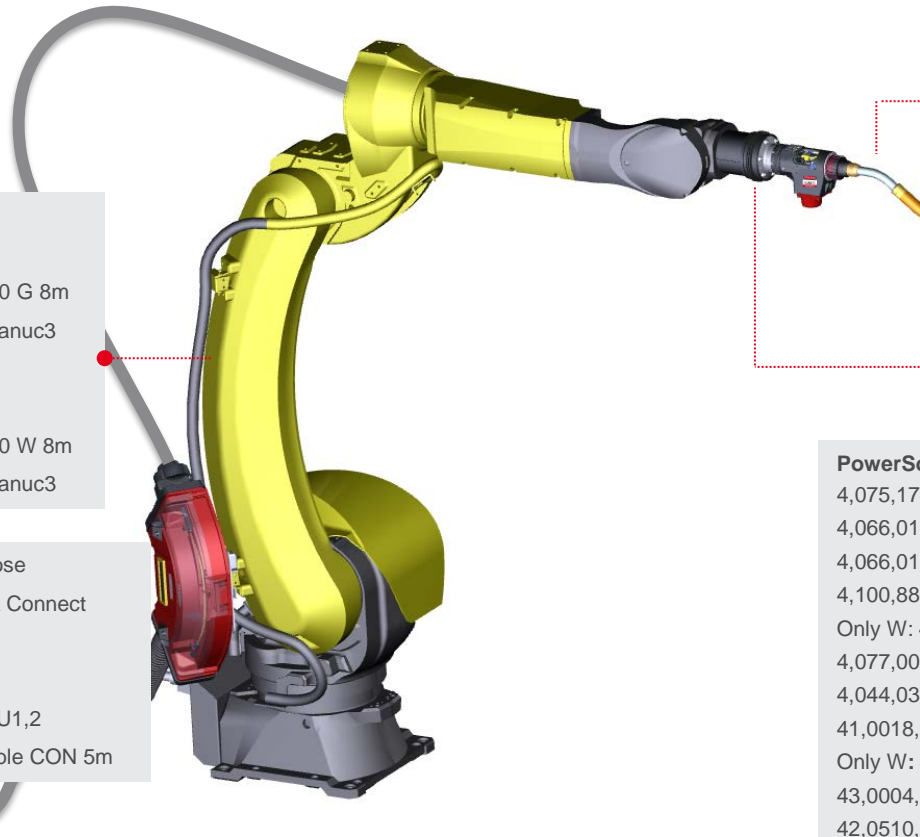

Gascooled version:

4,051,126 MHP 400i RD/G/FSC/2,265m
4,036,391 WF 60i Robacta Drive CMT/G
44,0350,3465 MTB 400i G R/22°/L241
44,0350,5316 BK CMT AI ø1,2 G

Watercooled version:

4,051,127 MHP 500i
RD/W/PAP/FSC/2,265m
4,036,390 WF 60i Robacta Drive CMT/W
44,0350,3494 MTB 500i W R/22°/L241
44,0350,5322 BK CMT AI ø1,2 W

44,0350,4392 RFP i 64 PAP 8M4 71
44,0350,3379 CrashBox Drive /i PAP XL

PowerSource:

4,075,174 TPS 400i
4,066,013 Welding Process Pulse
4,066,016 Welding Process CMT
4,100,886,1K OPT/i TPS 4xSwitch SpeedNet
Only W: 4,100,808,1K OPT/i TPS 2. NT241 CU 1400i /IK
4,077,001 Podium
4,044,035 RI FB/i Fanuc 1.0
41,0018,0084 RI MOD/i CC Ethernet/IP
Only W: 4,048,004,633 CU 1400i Pro MC
43,0004,2262 Earth cable 70mm² 10m cable lug
42,0510,0011 Pressure control valve Ar/CO₂ 3-30l/min

/ Perfect Welding / Solar Energy / Perfect Charging



All information is without guarantee in spite of careful editing - liability excluded.

Intellectual property and copyright: all rights reserved. Copyright law and other laws protecting intellectual property apply to the content of this presentation and the documentation enclosed (including texts, pictures, graphics, animations etc.) unless expressly indicated otherwise. It is not permitted to use, copy or alter the content of this presentation for private or commercial purposes without explicit consent of Fronius.